

MCK100

Part Danafoos
پارت دنافوز



Voltage	380V
Roping	2:1
Wrap	Single
Elv. Load	(320~630)kg
Elv. Speed	(0.5~1.75)m/s
Sheave Diam	320mm
Duty	S5-40%ED
Max. Static Load	2500kg
Weight	250kg
Brake	DC110V 2×1.3A
IP Code	IP41
Ins. Class	F

Dimensions

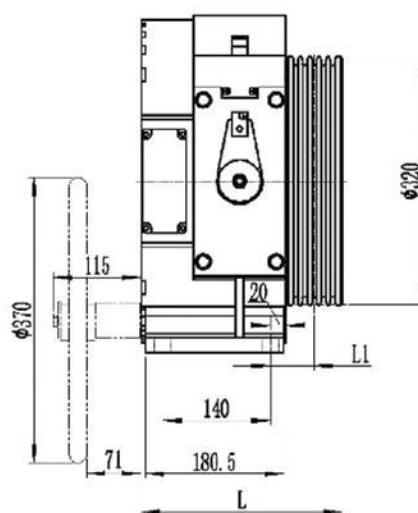
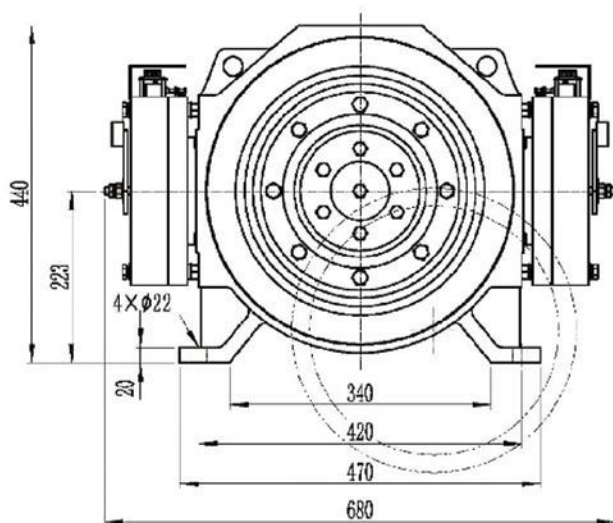

Spec. Sheet

Type	Spec	Elv Load	Elv Speed	Sheave Dia	Sheave Groove	Current	Power	Speed	Freq	Torque	Poles	L	L1	Undercut Angle
		kg	m/s	mm		A	kW	r/min	Hz	N-m		mm	mm	°
MCK100	320-0.5A	320	0.5	320	3×Φ8×12	3	1.1	60	10.0	180	20	251	52	95
MCK100	320-0.63A	320	0.63	320	3×Φ8×12	3	1.4	75	12.5	180	20	251	52	
MCK100	320-1.0A	320	1.0	320	3×Φ8×12	5	2.2	119	19.8	180	20	251	52	
MCK100	320-1.5A	320	1.5	320	3×Φ8×12	8	3.4	179	29.8	180	20	251	52	
MCK100	450-0.5A	450	0.5	320	4×Φ8×12	5	1.5	60	10.0	240	20	251	52	
MCK100	450-0.63A	450	0.63	320	4×Φ8×12	5	1.9	75	12.5	240	20	251	52	
MCK100	450-1.0A	450	1.0	320	4×Φ8×12	7	3	119	19.8	240	20	251	52	
MCK100	450-1.5A	450	1.5	320	4×Φ8×12	11	4.5	179	29.8	240	20	251	52	
MCK100	450-1.75A	450	1.75	320	4×Φ8×12	11	5.3	209	34.8	240	20	251	52	
MCK100	630-0.5A	630	0.5	320	5×Φ8×12	7	2.1	60	10.0	340	20	261	57	
MCK100	630-0.63A	630	0.63	320	5×Φ8×12	7	2.7	75	12.5	340	20	261	57	
MCK100	630-1.0A	630	1.0	320	5×Φ8×12	10	4.2	119	19.8	340	20	261	57	
MCK100	630-1.5A	630	1.5	320	5×Φ8×12	16	6.4	179	29.8	340	20	261	57	
MCK100	630-1.6A	630	1.6	320	5×Φ8×12	16	6.8	191	31.8	340	20	261	57	
MCK100	630-1.75A	630	1.75	320	5×Φ8×12	16	7.4	209	34.8	340	20	261	57	

Remark:

1. This model could be used for either machine room elevator or machine roomless elevator.
2. AC220V rectifier for brake is optional.
3. The above value of undercut angle is recommended based on regular standard. It's optional according to practical condition.